

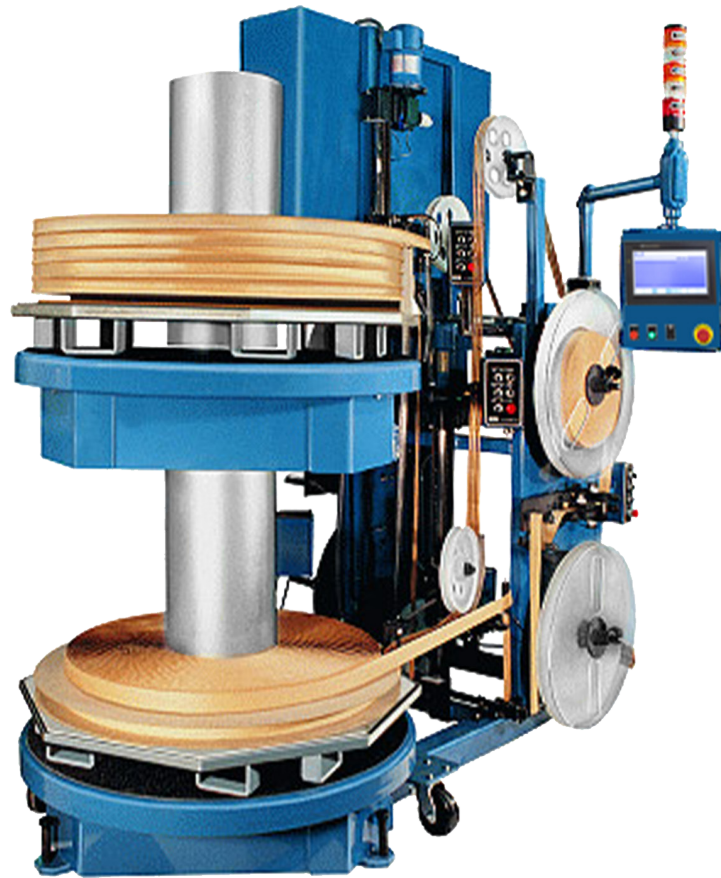

Wyndmaster 550T

Horizontal Pallet Winding System



DESCRIPTION

The Wyndmaster 550T is a Horizontal Pallet Coiling System for single and dual strip applications. The dual 44" 4500lb over and under table arrangement offers maximum space utilization.

Each table will provide a multilayer product package up to 26" high. An automatic powered product feeder automatically indexes to the next layer after completion of the current layer requirements. Each full layer requirements is programmable as number of parts on the part strip, product length, or final fill diameter.

The system will automatically slave itself to product feed rates up to 129ft/min (at a 12" core diameter) through either a dancer, a non-contact loop control, or a proprietary part count method.

A touch screen operator interface provides programmability, diagnostics, and displays current system parameters. A "systems status" light tower provides the operator with the current system condition at a distance.

Product control is achieved through the use of a microprocessor controlled system which maintains product integrity throughout the entire coiling/decoiling process. Special tension control and feedback systems are optionally available for precise product handling. An optional tangential feeder is available for handling very delicate products.



Customized Products
For Any Applications!

jcrautomation.com

JCR Automation
1426 Ryan Rd
New Haven, IN 46774
Phone: 260-493-6606



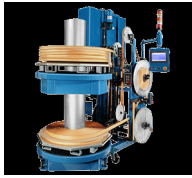

Wyndmaster 550T

Specifications

POWER REQUIREMENTS

208 VAC 3 Phase w/in @ 20 Amps /Leg

FEED RATE CAPABILITY

129 FPM @ 12" Diameter Core-Standard (Others Available Upon Request)

MATERIAL WIDTH (MAX)

2.5 Inches

TABLE DIAMETER

44 Inches

PALLET CAPACITY

4500 Pounds

FEED TRAVEL

26 Inches Vertical From Table

TABLE ROTATION

CW or CCW -Switch Selectable

TABLE SPINDLE MOTOR

1750 RPM, 1 HP,DC

PAINT COLOR

Vista Green (Per Customer Requirements)

PRODUCT FEED

Left to right or Right to left



Customized Products
For Any Applications!

jcrautomation.com

JCR Automation
1426 Ryan Rd
New Haven, IN 46774
Phone: 260-493-6606

