

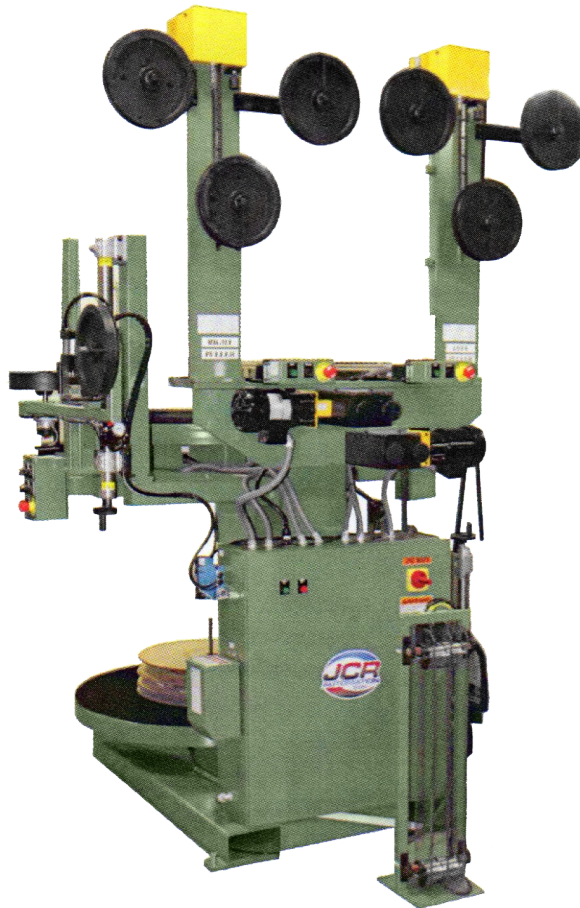

# Wyndmaster 550P

Horizontal Pallet Winding System  
Dual Strip Payout



## FEATURES

- Dual Table Platform with Non-Skid Surface
- CW or CCW Operation
- Variable Feed Rate
- Ultrasonic Loop Control

## OPTIONS

- Custom Product Tooling
- Single or Two Spindle Paper Interleaf Take-up



Customized Products  
For Any Applications!

[jcrautomation.com](http://jcrautomation.com)

JCR Automation  
1426 Ryan Rd  
New Haven, IN 46774  
Phone: 260-493-6606





# Wyndmaster 550P

## Specifications

### POWER REQUIREMENTS

240 VAC 1 Phase @ 30 Amps

### FEED RATE CAPABILITY

120 FPM @ 9" Diameter Core-Standard  
(Others Available Upon Request)

### MATERIAL WIDTH (MAX)

2.5 Inches

### TABLE DIAMETER

44 Inches

### PALLET CAPACITY

4500 Pounds

### FEED TRAVEL

26 Inches Vertical From Table

### TABLE ROTATION

CW or CCW - Switch Selectable

### TABLE SPINDLE MOTOR

1750 RPM, 1 HP

### AIR SUPPLY

80 PSI @ < 5SCFM

### PAINT COLOR

Vista Green (Per Customer Requirements)

### PRODUCT FEED

Left to right or Right to left

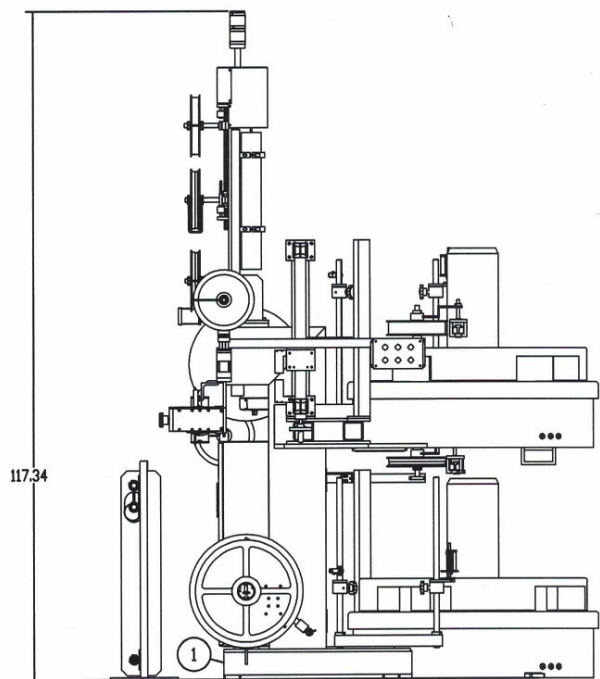
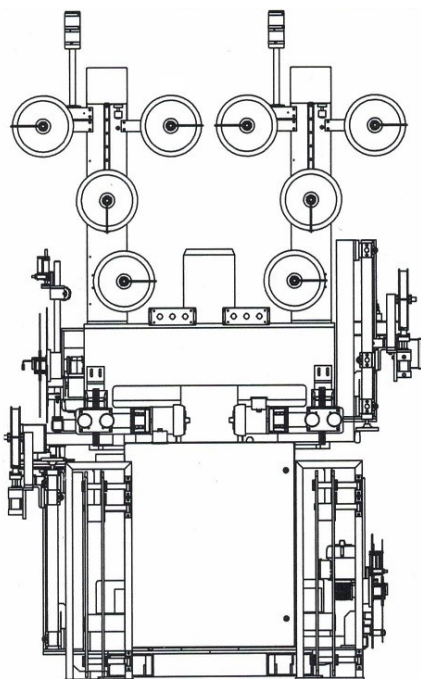
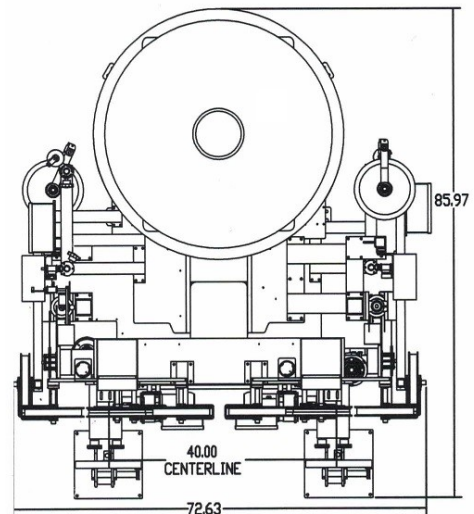

Customized Products  
For Any Applications!

[jcrautomation.com](http://jcrautomation.com)

JCR Automation  
1426 Ryan Rd  
New Haven, IN 46774  
Phone: 260-493-6606

