



Wyndmaster 501T

Horizontal Pallet Winding System-Single Strip Take-up



FEATURES

- Single Table Platform
- CW or CCW Table Operation
- Variable Feed Rate

OPTIONS

- Custom Product Tooling
- Single Spindle Paper Interleaf (Shown)
- Ultrasonic Loop Control



Customized Products
For Any Applications!

jcrautomation.com

JCR Automation
1426 Ryan Rd
New Haven, IN 46774
Phone: 260-493-6606





Wyndmaster 501T

Specifications

POWER REQUIREMENTS

120 VAC, 20A

ROTATION

CW or CCW

MATERIAL WIDTH (MAX)

2 Inches

PALLET TABLE DIAMETER

44 Inches

FEED RATE CAPABILITY

Variable up to 1200 IPM

PALLET CAPACITY

4500 Pounds

FEED DIRECTION

Left to right or right to left (Per Customer Requirements)

MOTOR

1750 RPM, 1 HP

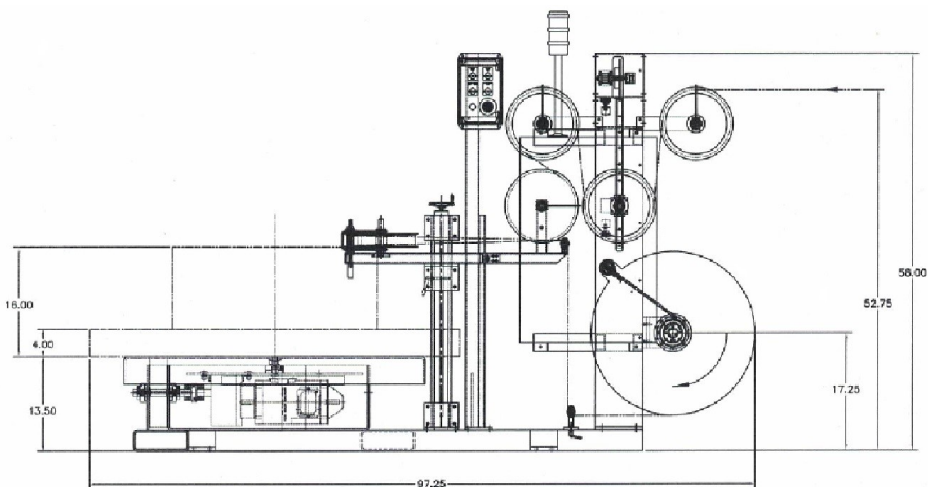
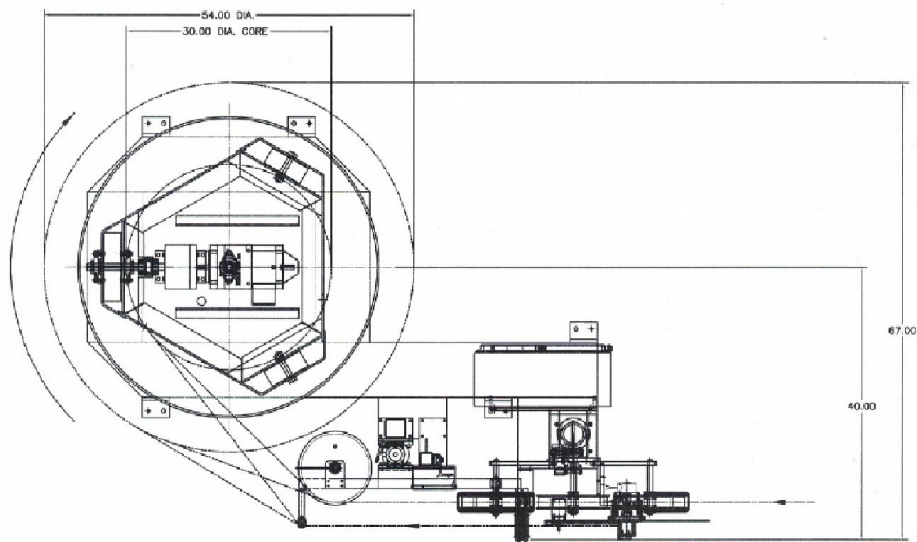

Customized Products
For Any Applications!

jcrautomation.com

JCR Automation
1426 Ryan Rd
New Haven, IN 46774
Phone: 260-493-6606

