

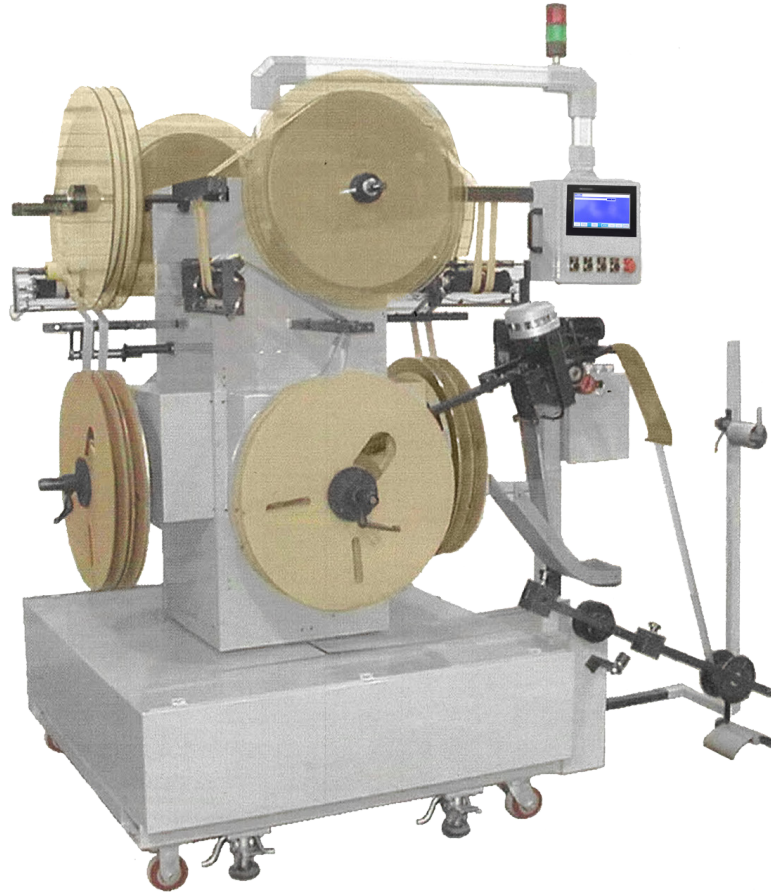

Wyndmaster 348

Eight Spindle Automatic Take-up System



FEATURES

- Automatic Reel Transfer
- Selectable Overwind / Underwind Operation
- Non-Contact PC Loop Control
- Tangential Product Feeder
- Adjustable Paper Tension Control
- Sample Strip with Programmable Cut Location
- Single Strip Operation
- Eight Reel Capacity

OPTIONS

- Dancer Loop Control (Shown)
- Programmable Product Tension
- Programmable Paper Tension
- High Speed / High Torque Motors
- Material Component Selection for Corrosive Environments



Customized Products
For Any Applications!

jcrautomation.com

JCR Automation
1426 Ryan Rd
New Haven, IN 46774
Phone: 260-493-6606





Wyndmaster 348

Specifications

POWER REQUIREMENTS

120 VAC, single phase, 20A

AIR SUPPLY

80 PSI

MATERIAL WIDTH (MAX)

2.5 Inches

REEL DIAMETER (MAX)

30 Inches (others available on request)

FEED RATE CAPABILITY

750 IPM

REEL CENTER CORE

5.0 inches

(others available upon request)

FEED DIRECTION

Left to right or right to left (Per Customer Requirements)

SPINDLE MOTORS

3/8 HP, 85 RPM, AC

SPINDLE DIAMETER

(Per Customers request)

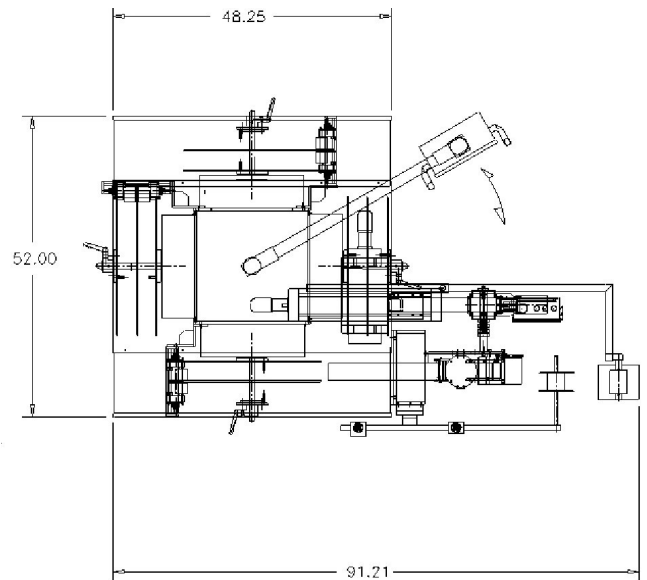
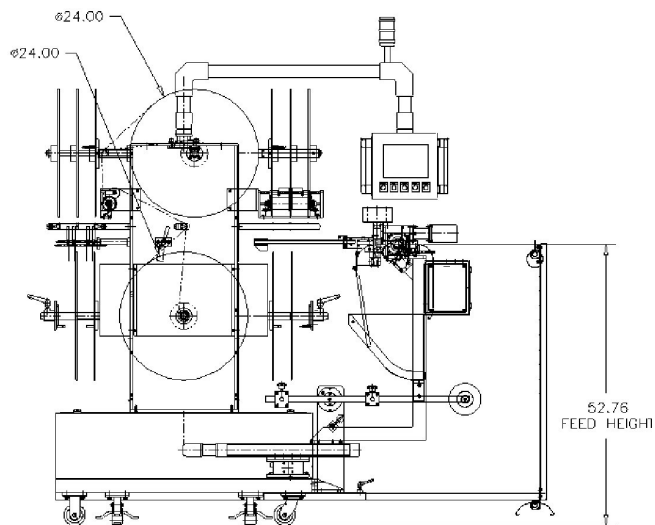

Customized Products
For Any Applications!

jcrautomation.com

JCR Automation
1426 Ryan Rd
New Haven, IN 46774
Phone: 260-493-6606

