



Wyndmaster 324P

Four Spindle Automatic Take-up System



FEATURES

- Automatic Cut and Transfer
- Overwind Operation
- Non-Contact Loop Control
- Single Strip Operation
- Four Reel Capacity
- Programmable Paper Tension
- Four Spindle Operator Start Paper Interleaf
- Tangential Product Feeder
- Part Counter with Operator Alert System
- Programmable Operator Interface with Diagnostics
- Quick Release Reel Flanges
- Sample Strip with Programmable Cut Location

OPTIONS

- Dancer Loop Control
- High Speed / High Torque Motors
- Material Component Selection for Corrosive Environment



Customized Products
For Any Applications!

jcrautomation.com

JCR Automation
1426 Ryan Rd
New Haven, IN 46774
Phone: 260-493-6606





Wyndmaster 324P

Specifications

POWER REQUIREMENTS

120 VAC, single phase, 15A

AIR SUPPLY

80 PSI

MATERIAL WIDTH (MAX)

3 Inches (others available on request)

REEL DIAMETER (MAX)

36 Inches (others available on request)

FEED RATE CAPABILITY

800 IPM

REEL CENTER CORE

5.0 inches (others available upon request)

FEED DIRECTION

Left to right or right to left (Per Customer Requirements)

SPINDLE MOTORS

76 RPM, 1/8 HP, DC

SPINDLE DIAMETER

0.75 Inches (Standard, others available on request)

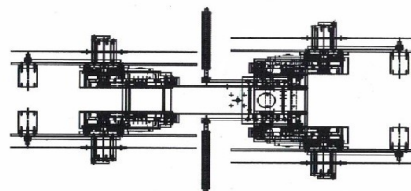
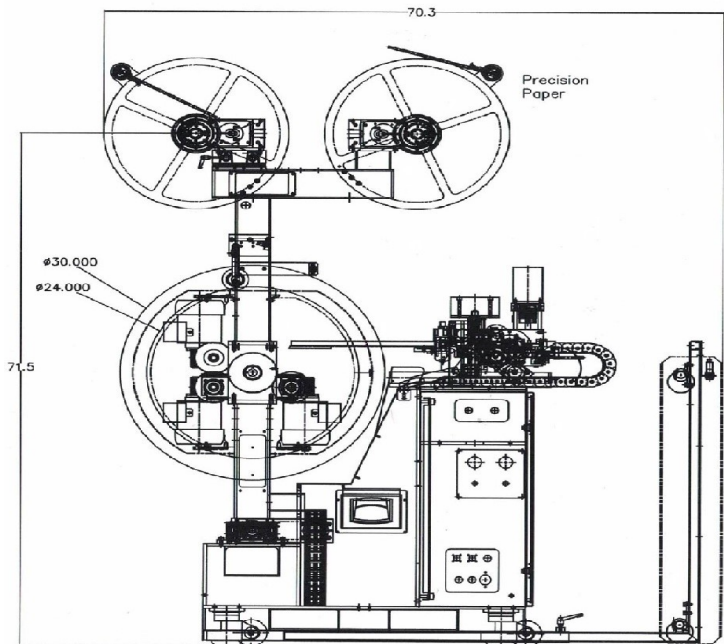
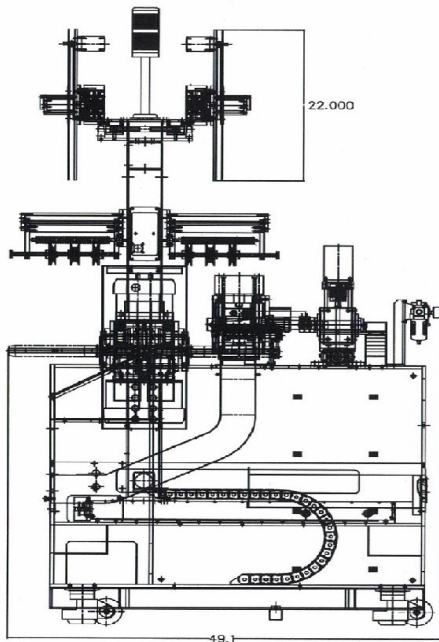

Customized Products
For Any Applications!

jcrautomation.com

JCR Automation
1426 Ryan Rd
New Haven, IN 46774
Phone: 260-493-6606

