

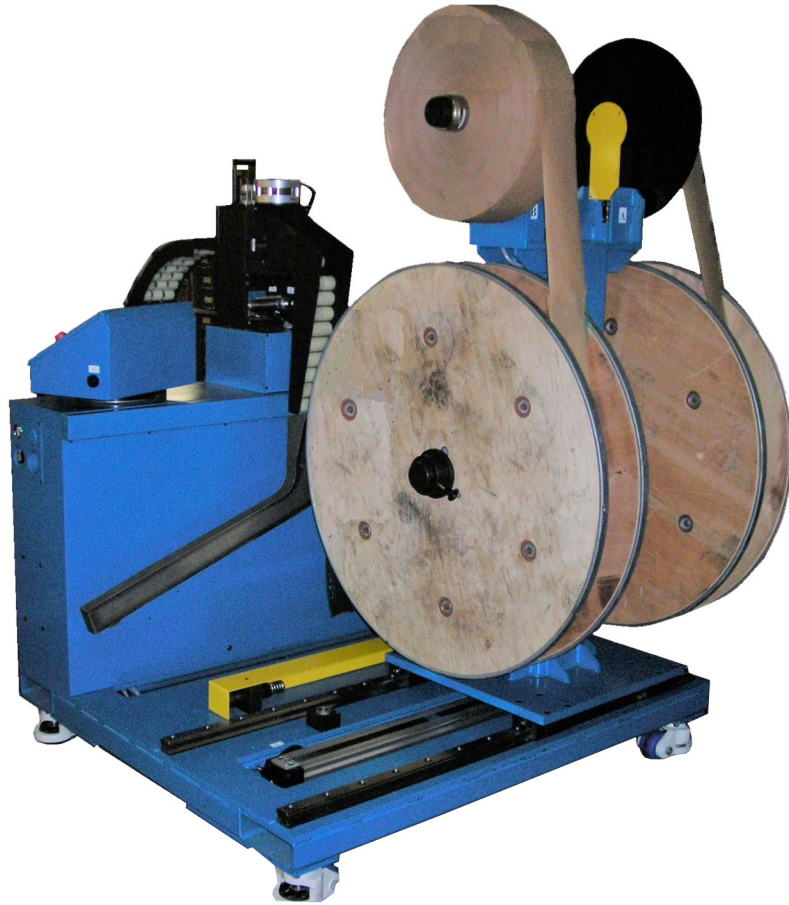

Wyndmaster 320HD

Two Spindle Automatic Take-up System



FEATURES

- Single Strip Operation
- Two Reel Capacity
- Automatic Reel Transfer
- Ultrasonic Loop Control
- Sample Strip with Programmable Cut Location
- Operator Start Paper Interleaf with Programmable Tensioning

OPTIONS

- Integrated Vision Inspection System
- Dancer Loop Control
- Material Component Selection for Corrosive Environments



Customized Products
For Any Applications!

jcrautomation.com

JCR Automation
1426 Ryan Rd
New Haven, IN 46774
Phone: 260-493-6606





Wyndmaster 320HD

Specifications

POWER REQUIREMENTS

120 VAC, single phase, 20A

AIR SUPPLY

80 PSI

MATERIAL WIDTH (MAX)

7 Inches

REEL DIAMETER (MAX)

48 Inches (others available on request)

FEED RATE CAPABILITY

360 IPM

REEL CENTER CORE

18.5 inches (others available upon request)

FEED DIRECTION

Left to right or right to left (must be specified).

SPINDLE MOTOR

1/2 HP

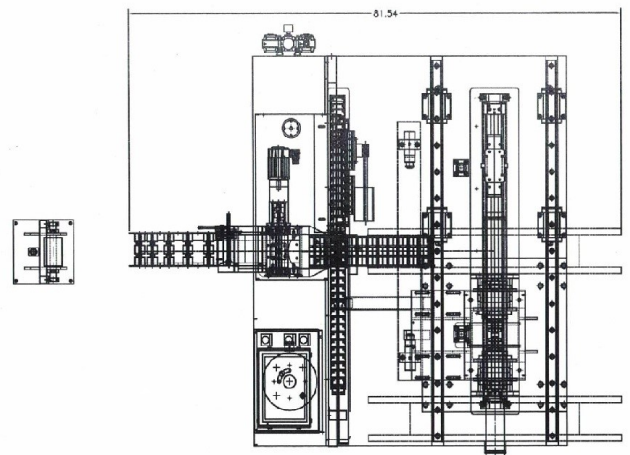
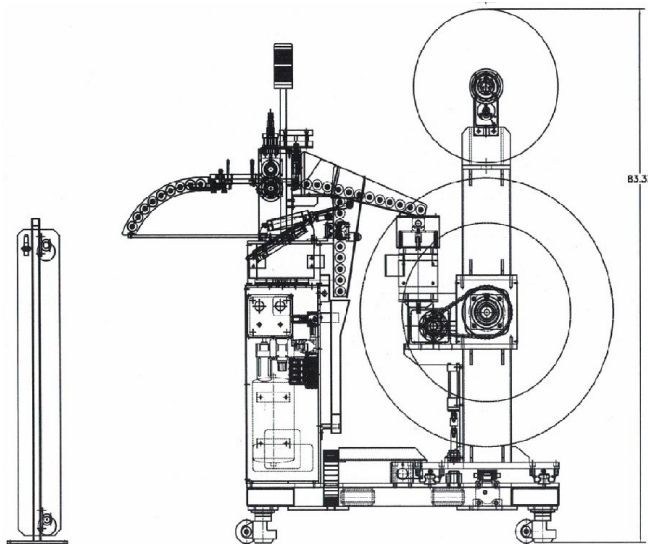
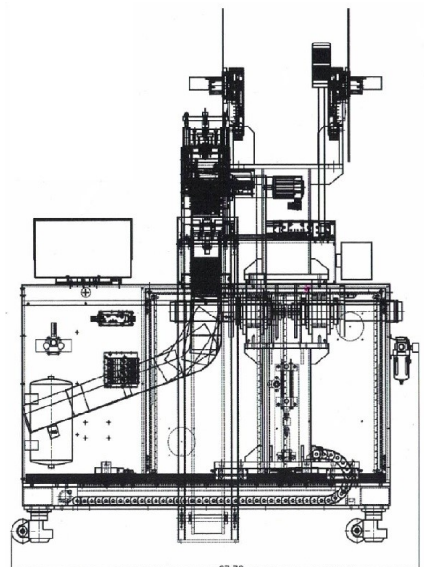

Customized Products
For Any Applications!

jcrautomation.com

JCR Automation
1426 Ryan Rd
New Haven, IN 46774
Phone: 260-493-6606

