

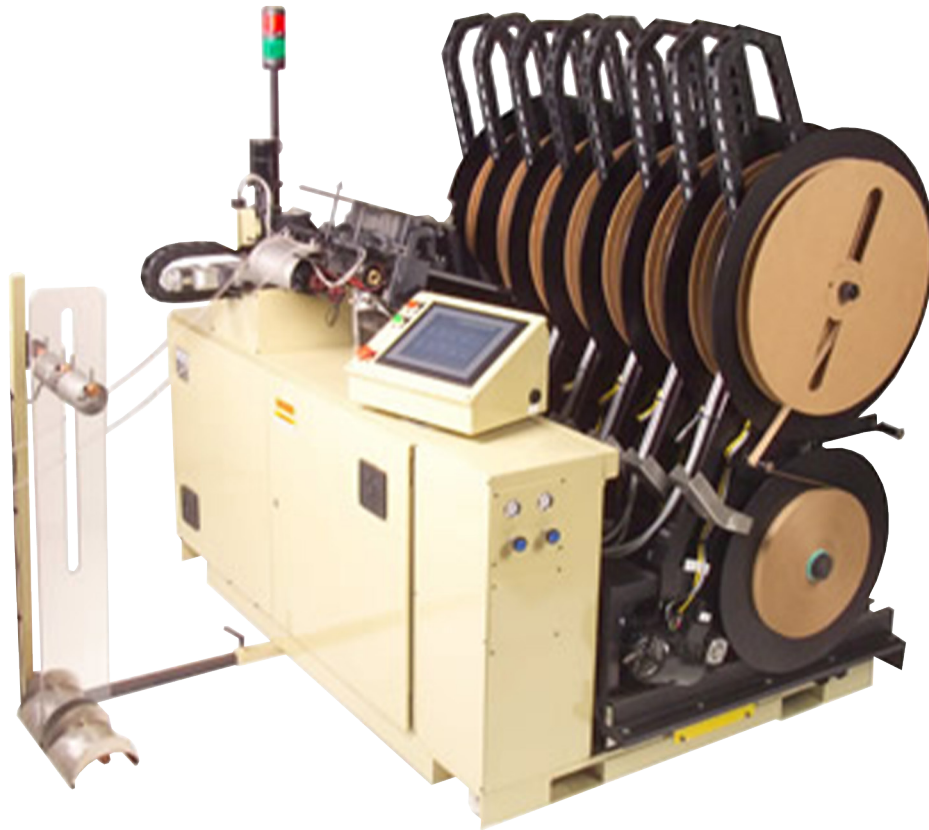

# Wyndmaster 3208

## Eight Spindle Automatic Take-Up System



### FEATURES

- Single Strip Operation
- Eight Reel Capacity
- Automatic Reel Transfer
- Selectable Overwind / Underwind Operation
- Non-Contact PC Loop Control
- Tangential Product Feeder
- Sample Strip with Programmable Cut Location
- Operator Start Paper Interleaf with Programmable Tensioning

### OPTIONS

- Integrated Vision Inspection System
- Dancer Loop Control
- Ultrasonic Loop Control
- Dual Strip Operation (Shown)
- Material Component Selection for Corrosive Environments



Customized Products  
For Any Applications!

[jcrautomation.com](http://jcrautomation.com)

JCR Automation  
1426 Ryan Rd  
New Haven, IN 46774  
Phone: 260-493-6606



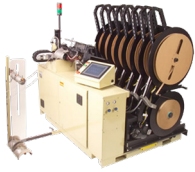

# Wyndmaster 3208

## Specifications

### POWER REQUIREMENTS

120 VAC, single phase, 20 A

### AIR SUPPLY

80 PSI

### MATERIAL WIDTH (MAX)

2 Inches

### SPINDLE DIAMETER

(Per Customers request)

### FEED RATE CAPABILITY

650 IPM

### Reel Diameter (Max):

36 inches with 18 inch paper diameter  
 30 inches with 24 inch paper diameter  
 (others available upon request)

### FEED DIRECTION

Left to right or right to left (Per Customer Requirements)

### SPINDLE MOTORS

80 RPM, 1/4 HP AC (Standard/others available upon request)

### REEL CENTER CORE

5.0 inches (Standard/others available upon request)

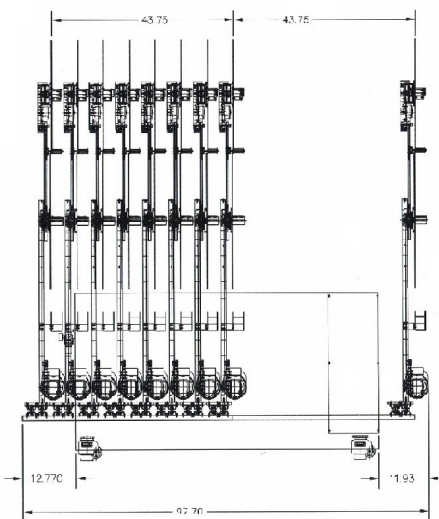
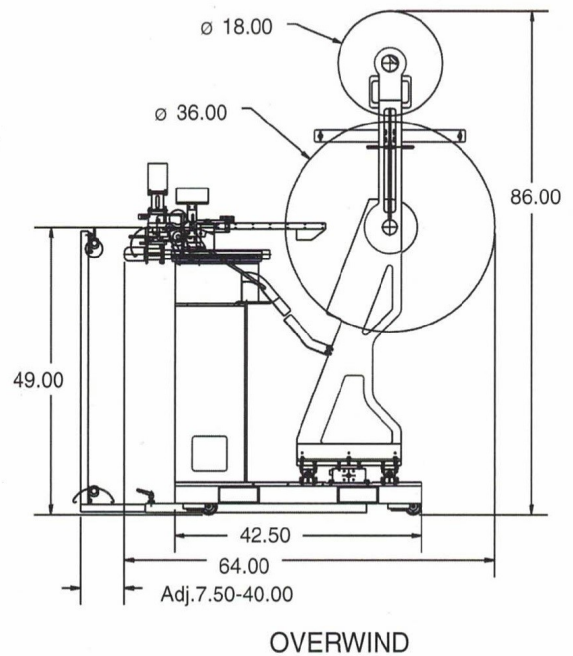
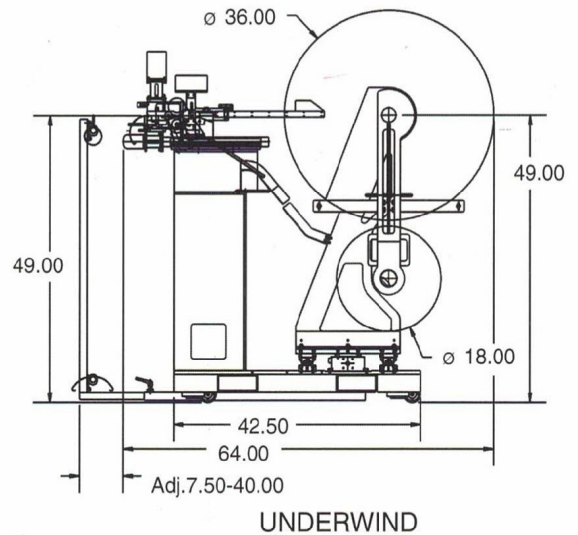

Customized Products  
For Any Applications!

[jcrautomation.com](http://jcrautomation.com)

JCR Automation  
1426 Ryan Rd  
New Haven, IN 46774  
Phone: 260-493-6606

