



Wyndmaster 3204

Four Spindle Automatic Take-Up System



FEATURES

- Single Strip Operation
- Four Reel Capacity
- Automatic Reel Transfer
- Selectable Overwind / Underwind Operation Non-Contact PC Loop Control
- Tangential Product Feeder
- Sample Strip with Programmable Cut Location
- Operator Start Paper Interleaf with Programmable Tensioning

OPTIONS

- Integrated Vision Inspection System
- Dancer Loop Control
- Ultrasonic Loop Control
- Material Component Selection for Corrosive Environments



Customized Products
For Any Applications!

jcrautomation.com

JCR Automation
1426 Ryan Rd
New Haven, IN 46774
Phone: 260-493-6606





Wyndmaster 3204

Specifications

POWER REQUIREMENTS

120 VAC, single phase, 20 A

AIR SUPPLY

80 PSI

MATERIAL WIDTH (MAX)

2 Inches

SPINDLE DIAMETER

(Per Customers request)

FEED RATE CAPABILITY

650 IPM

Reel Diameter (Max):

36 inches with 18 inch paper diameter
 30 inches with 24 inch paper diameter
 (others available upon request)

FEED DIRECTION

Left to right or right to left (Per Customer Requirements)

SPINDLE MOTORS

80 RPM, 1/4 HP AC (Standard/others available upon request)

REEL CENTER CORE

5.0 inches (Standard/others available upon request)

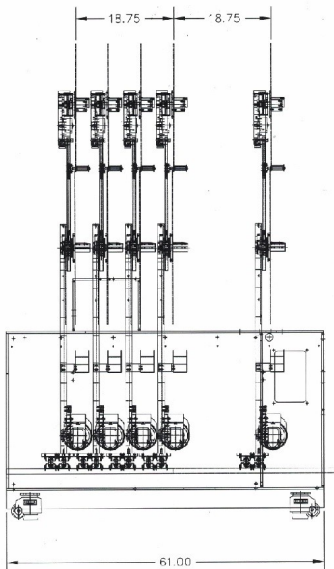
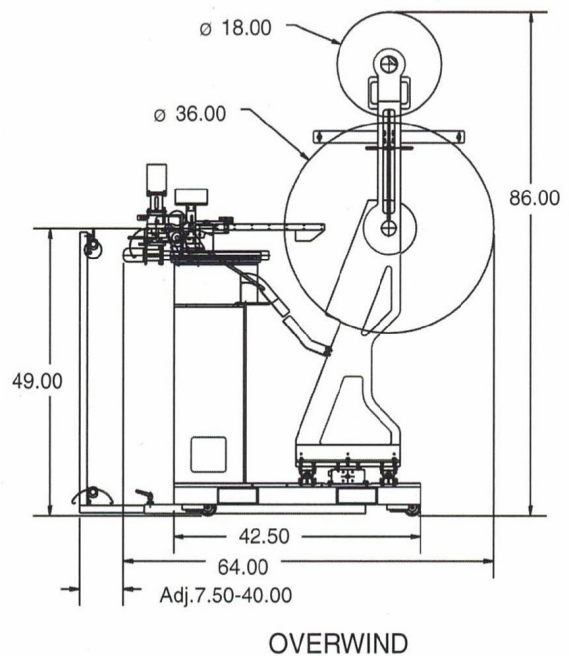
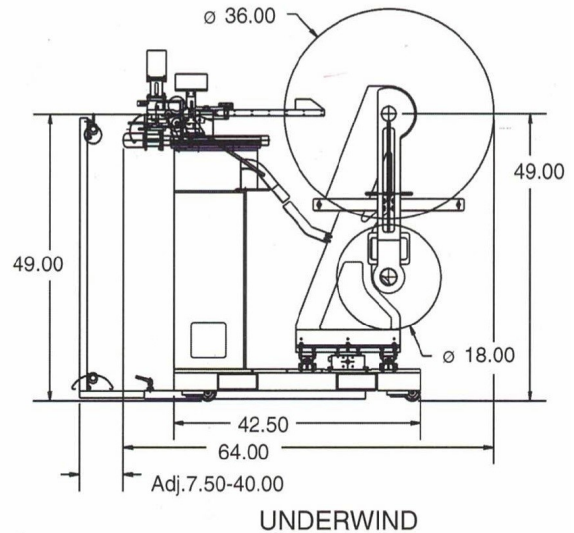

Customized Products
For Any Applications!

jcrautomation.com

JCR Automation
1426 Ryan Rd
New Haven, IN 46774
Phone: 260-493-6606

