



Wyndmaster 320

Two Spindle Automatic Take-up System



FEATURES

- Automatic Cut and Transfer
- Switch Selectable Overwind / Underwind Operation
- Non-Contact PC Loop Control
- Tangential Product Feeder
- Adjustable Paper Tension Control
- Part Counter with Operator Alert System
- Programmable Operator Interface with Diagnostics
- Quick Release Reel Flanges
- Sample Strip with Programmable Cut Location
- Single Strip Operation
- Two Reel Capacity

OPTIONS

- Operates with or without Paper Interleaf, requires latch fingers and product tensioning system
- Dancer Loop Control
- High Speed / High Torque Motors



Customized Products
For Any Applications!

jcrautomation.com

JCR Automation
1426 Ryan Rd
New Haven, IN 46774
Phone: 260-493-6606





Wyndmaster 320

Specifications

POWER REQUIREMENTS

120 VAC, single phase, 15A

AIR SUPPLY

80 PSI

MATERIAL WIDTH (MAX)

3 Inches (others available upon request)

REEL DIAMETER (MAX)

36 Inches

FEED RATE CAPABILITY

800 IPM without accumulator

REEL CENTER CORE

5.0 inches

(others available upon request)

FEED DIRECTION

Left to right or right to left (must be specified).

SPINDLE MOTOR

1/8 HP, 76 RPM, DC

SPINDLE DIAMETER

0.75 inches

(standard, others available upon request)

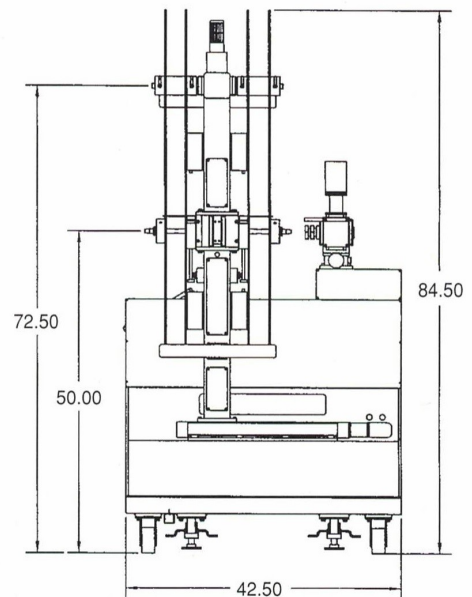
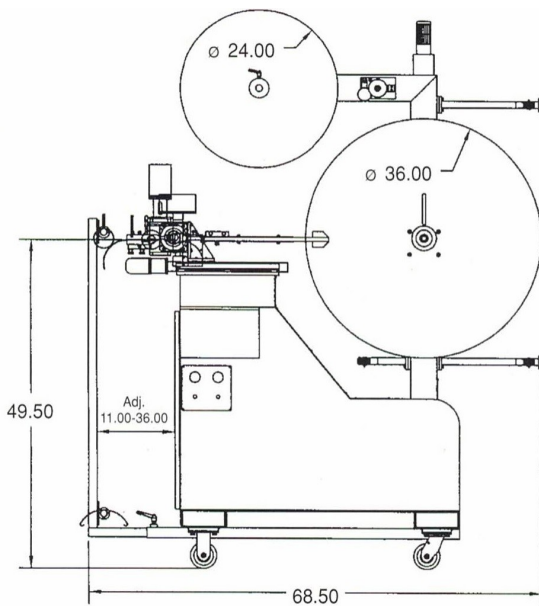

Customized Products
For Any Applications!

jcrautomation.com

JCR Automation
1426 Ryan Rd
New Haven, IN 46774
Phone: 260-493-6606

