



Wyndmaster 300-2

Eight Spindle Automatic Take-up System



FEATURES

- Dual strip operation
- Eight reel capacity
- Dancer loop and tension control
- Part / Length counter with operator alert system
- Programmable operator interface with diagnostics
- Quick release reel flanges
- Casters and floor brakes

OPTIONS

- Single spindle paper interleaf
- Sonic non-contact loop control
- Part count non-contact loop control
- High speed / high torque motors
- Part strip locator
- In-feed puller with encoder
- Tail retention gripper
- Over center locking latch fingers
- Material component selection for corrosive environments



Customized Products
For Any Applications!

jcrautomation.com

JCR Automation
1426 Ryan Rd
New Haven, IN 46774
Phone: 260-493-6606





Wyndmaster 300-2

Specifications

POWER REQUIREMENTS

120 VAC, single phase, 10A

AIR SUPPLY

80 PSI @ 5 SCFM

MATERIAL WIDTH (MAX)

3 Inches.

REEL DIAMETER (MAX)

24 Inches

FEED RATE

800 IPM

PAINT COLOR

Vista Green (or Per Customer Requirements)

PRODUCT FEED

Left to right or right to left (must be specified).

SPINDLE CONFIGURATION

Tooled To Customers Reel

SPINDLE MOTOR

1/8 HP, 76 RPM, DC

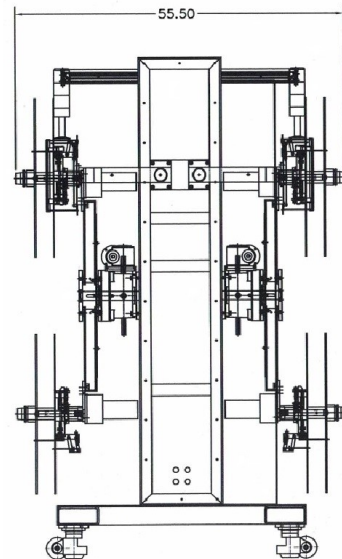
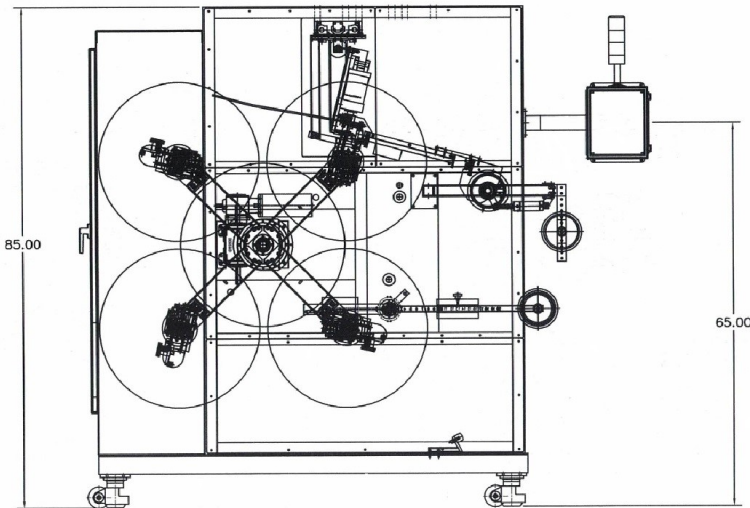
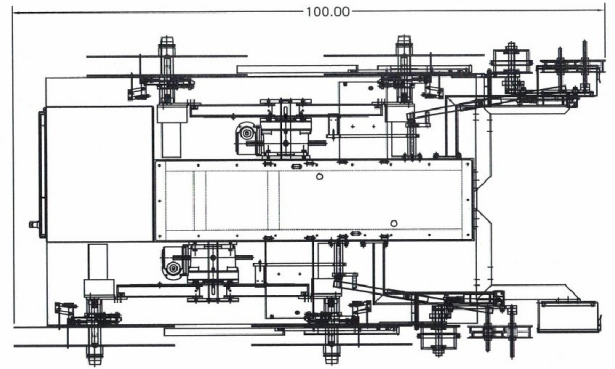

Customized Products
For Any Applications!

jcrautomation.com

JCR Automation
1426 Ryan Rd
New Haven, IN 46774
Phone: 260-493-6606

