



Wyndmaster 100

Take-Up and Payout System



FEATURES

- Simple Operator Controls
- Variable Speed DC Spindle Drive
- Dancer Loop Control
- Quick Lock Hub
- Adjustable Tension
- Selectable Take-up / Payout Operation
- Selectable Overwind / Underwind Operation

OPTIONS

- Non-Contact Loop Control
- Paper Interleaf
- Spindle Adapters to Accept Various Reel Cores
- Collapsible Mandrel
- High or Low Limit Shutdown Contacts



Customized Products
For Any Applications!

jcrautomation.com

JCR Automation
1426 Ryan Rd
New Haven, IN 46774
Phone: 260-493-6606





Wyndmaster 100

Specifications

POWER REQUIREMENTS

120 VAC, single phase, 5A

MATERIAL WIDTH (MAX)

3.0 Inches

REEL DIAMETER (MAX)

32.0 Inches / 48.0 Inches (optional)

SPINDLE MOTOR

76 RPM, 1/8 HP, DC

FEED RATE CAPACITY

1200 IPM @ 5" Core

SPINDLE DIAMETER

(Per Customer Request)

DRIVE PIN

(Per Customer Request)

PRODUCT TENSION

1- 5 lbs. Slide Weight

FEED DIRECTION

Left to Right or Right to Left (Per Customer Request)

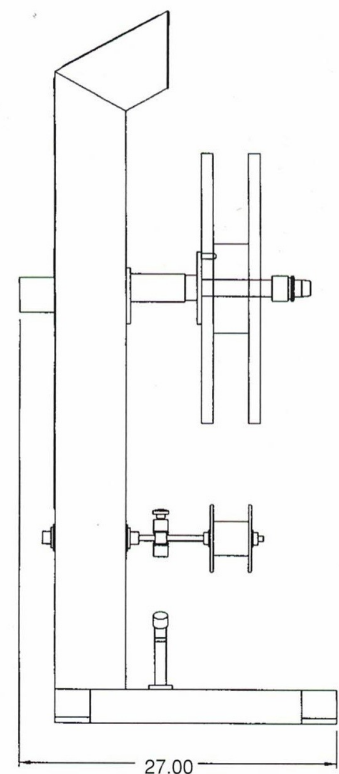
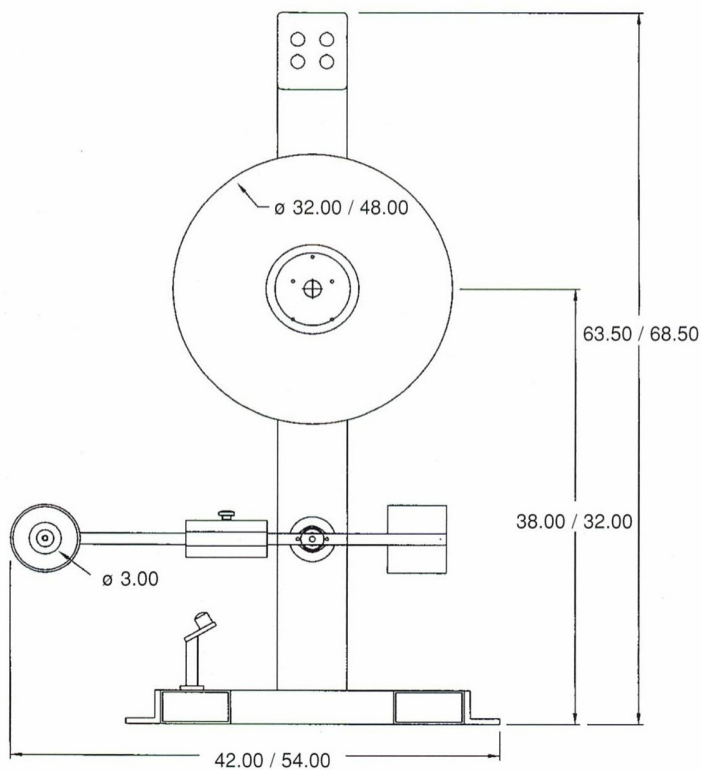

Customized Products
For Any Applications!

jcrautomation.com

JCR Automation
1426 Ryan Rd
New Haven, IN 46774
Phone: 260-493-6606

